



# TRB SAMPLE COOLER

## For Low Pressure Boiler Applications

*Compact, efficient sample cooling for industrial boiler samples*



**TRB SAMPLE COOLER**

### Features

- Helical coil design
- Ideal for cooling low pressure boiler water

### Description

The TRB sample cooler is a compact sample cooler that provides the industrial boiler user with a cost effective and efficient sampling alternative. It's small profile allows for easy installation on or near the boiler. Optimal service for flows below 1200 cc/min for single phase heat transfer. Standard tube side material is 300 series stainless steel.

### Performance Curve - Water

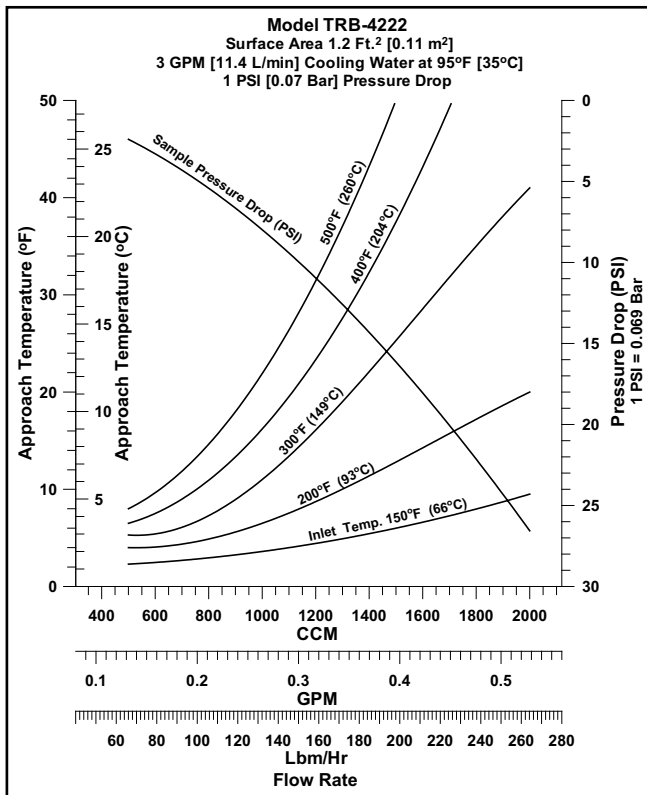

**NOTE:** Not recommended for steam condensing service. See TLR, FLR, FXR series sample coolers for this application.

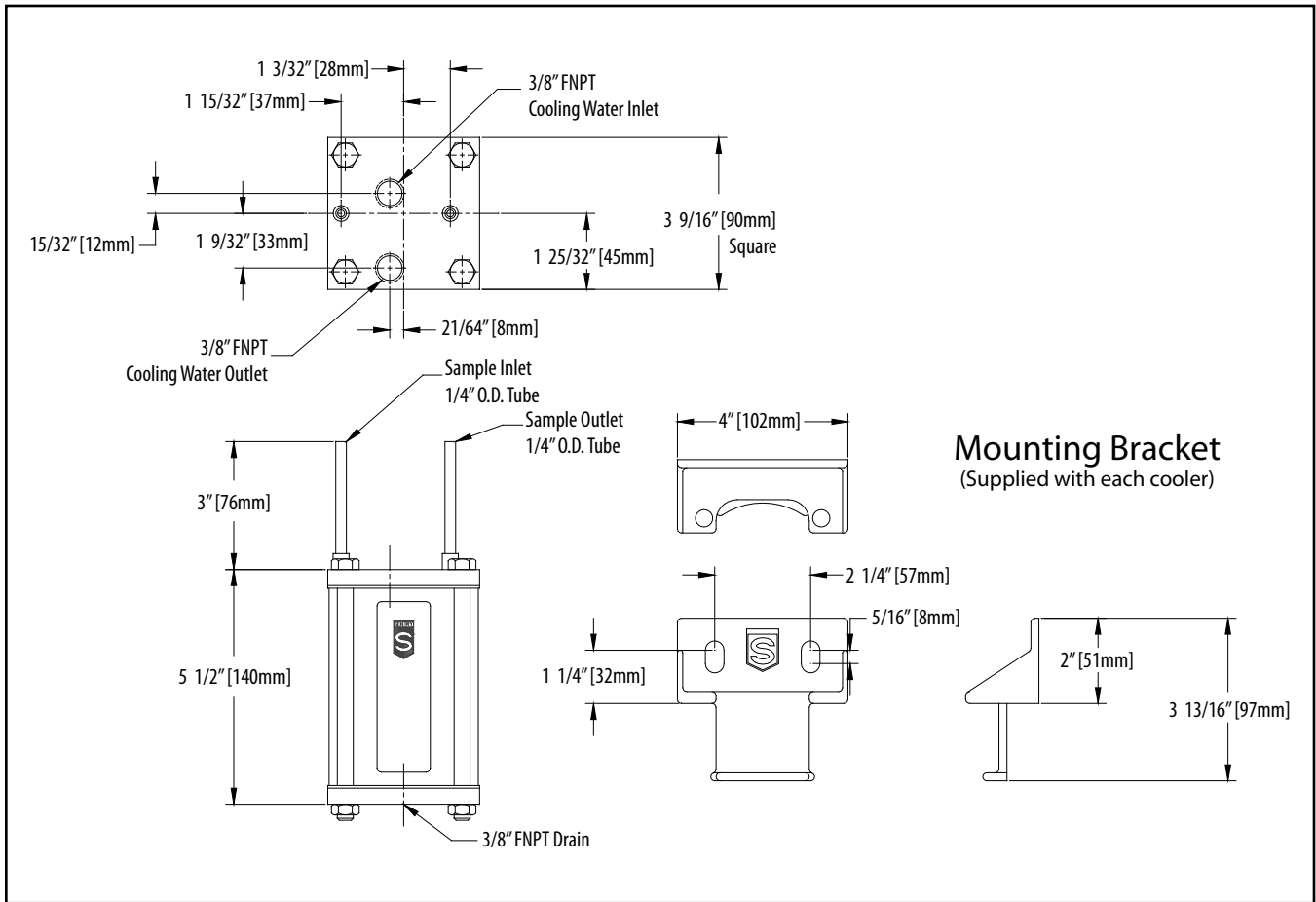

Specifications – TRB							
Model No.	Shell Design	Tube Design	Tube Material	Shell Material	Area	Weight	Part Number
TRB-4222	250 psi @ 450°F 17 bar @ 232°C	2000 psi @ 850°F 137 bar @ 454°C	300 Series SS 1/4" O.D. x 0.049" AW	304 SS	1.2 ft <sup>2</sup> 0.11m <sup>2</sup>	9 lbs 4 kg	7-00016A

**WARNING**

It is solely the responsibility of the end-user, through its own analysis and testing, to select products and materials suitable for their specific application requirements, ensure they are properly installed, safely applied, properly maintained, and limit their use to their intended purpose. Improper selection, installation, or use may result in personal injury or property damage.



**SENTRY EQUIPMENT CORP**

966 Blue Ribbon Circle North  
Oconomowoc, WI 53066 USA  
Tel: 262-567-7256 • Fax: 262-567-4523

E-mail:  
sales@sentry-equip.com

Website:  
www.sentry-equip.com

QUALITY MANAGEMENT SYSTEM  
CERTIFIED BY DNV  
ISO 9001:2008

For further information, contact: